

3

2

1

NOTES:

- 1 ALL DIMENSIONS SHOWN ARE IN Inches (mm)
- 2 ALL DIMENSIONS SHOWN ARE FINISH OPERATIONAL DIMENSIONS WHICH INCLUDE RESIDUAL COATINGS UNLESS OTHERWISE SPECIFIED.
- 3 PART TO BE FLAT PACKED PROPERLY TO AVOID ANY DAMAGE WHILE SHIPPING & HANDLING.
- 4 ALL HORIZONTAL DIMENSIONS ARE SYMMETRICAL ABOUT VERTICAL CENTER LINE UNLESS OTHERWISE SPECIFIED.

REVISIONS			
REV	DESCRIPTION	DATE	APPROVED
-	-	-	-

E

E

D

D

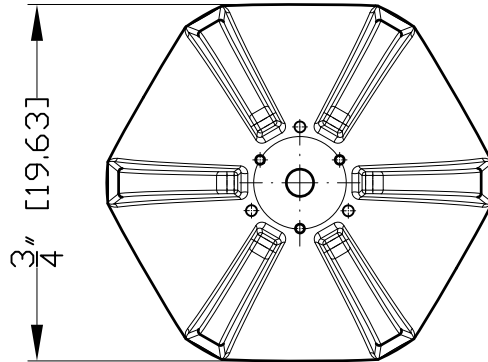

C

C

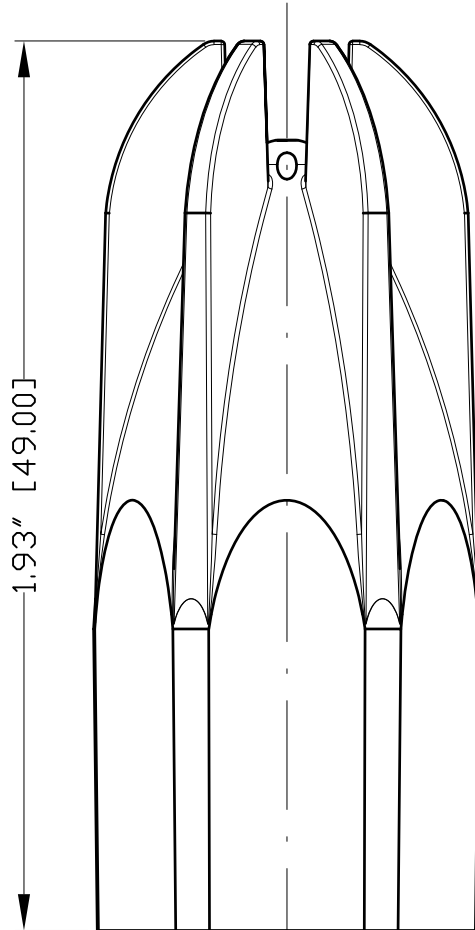

B

B

1/4" NPT (F) INLET

A

A

THIRD ANGLE PROJECTION		REQUIREMENTS—UNLESS OTHERWISE SPECIFIED GENERAL		CONTRACT NUMBER — CLIENT — CONTRACTOR —		NEX FLOW AIR PRODUCTS CORP. 10520 YONGE STREET, UNIT 35B-220, RICHMOND HILL, ON L4C 3C7 TEL.: (416) 410-1313 & FAX: (416) 410-1806 www.nex-flow.com					
		1. DIMS ARE IN INCHES (MM) 2. DIMENSIONING AND TOLERANCING IN ACCORDANCE WITH ANSI Y14.5 (1982) 3. MACHINE FINISH 125 MICRO INCH RMS 4. INTERNAL RADII .015 5. BREAK SHARP CORNERS .005 TO .015		DRAWN CHIRAG.S DATE 01/01/2016 DESIGN — CHECKED ASHISH PROJECT — Q.A. —		AIR MAG™ NOZZLE					
MATERIAL	CAST ZINC		LIMITS 1. LINEAR DIMS. .XXX = .005 .XX = .010 .X = .030 2. ANGLES = ± 1/2" 3. RUNOUT .010 TIR 4. HOLES IN ACCORDANCE WITH AND 10387		STRESS — MANUFACTURING — THERMAL — MATERIALS — MECHANISM — ELECTRICAL —		SIZE	CAGE CODE	PART NAME	RELEASE	REV
FINISH	—						—	—	47004 AMF	—	—
							SCALE	1:1		CAD NO	SHEET 1 OF 1

3

2

1